

ROKOMB

Technical data of Moog's ROKOMB standard product range combining rotary unions and slip rings.



ABOUT MOOG

Moog Inc. is a worldwide designer, manufacturer and integrator of precision control components and systems. Moog Industrial Group designs and manufactures highly reliable products, solutions and services using innovative motion control and power/data technologies. We combine world class technologies with expert consultative support in a range of applications such as energy, industrial machinery, marine, and simulation and test industries, to name a few. We help performance driven companies design and develop their next generation equipment.

Moog's standard and customized products have a long service life with minimal to no maintenance applications, ideal for demanding requirements in harsh environments. As a market leader, we use innovative engineering to combine and integrate our products, delivering the best solutions to our customers.

MOOG ROKOMB

Thanks to the ROKOMB system you can combine all our rotary unions and slip rings with each other. We can provide you a rotary transmission solution from a single source.

Your benefits with Moog ROKOMB systems

- Liquids, gas, vacuum as well as electrical currents, signals and data
- No interface issues between the individual components
- Huge time and cost savings in the administrative effort
- Customer-specific, modular, compact solutions

Our systems of rotary unions and slip rings ensure that an optimally adapted sealing system is available for any medium. For any type of electrical transmission, a corresponding system is selected to ensure adequate reliability. Thanks to the modular design, individual components can be replaced, retrofitted or upgraded as necessary.

DESIGNED TO SUIT YOUR APPLICATIONS

All components are selected and combined to meet your specific demands, without limitations to the number of electrical poles, media or size. Special solutions such as ATEX/IECEX or certifications according to UL/CSA regulations are also available on request.

This data sheet shows a selection of standard variants - all other versions (e.g. for higher speeds/specific electrical assignments) are available on request. Step files for the components shown are available for download at:

<https://www.gat-mbh.de/produkte/rotokombi/>

MOOG ROTARY UNIONS

LEAKAGE-FREE AND WEAR-RESISTANT

The elastomer sealing systems developed inhouse and the special coatings of the shaft ensure minimal wear and reliable operation without leakage of the rotary unions – despite the contacting seal.

MINIMIZED DOWNTIMES

Moog's rotary unions perform with absolute reliability even when subject to extreme loads and the most challenging operating conditions. Engineered to customer specifications, they reduce downtimes at offshore oil and gas production plants to the minimum while at the same time enhancing safety and reliability.

YOUR REQUIREMENTS – OUR SOLUTIONS

Thanks to their special design principle, rotary unions meet any requirement, providing a tailor-made, reliable and profitable solution. Even if demands in terms of pressure, speed, torque and seal diameter are high.

MOOG SLIP RINGS

FOR RELIABLE TRANSMISSION

The successful and established technology from Moog makes slip rings a reliable partner for the transmission of power, signals and data. For field-bus or Ethernet communication or the transfer of most delicate analog measuring signals.

LOW MAINTANANCE AND ULTIMATE DURABILITY

Our evaluated combination of a collector with six contact points and our specially coated slip ring tracks (depending on application requirements) ensures an unsurpassed service life with a consistently high signal quality.

Rugged plastic housings ensure operation even under extreme environmental conditions.

STANDARD AND CUSTOMIZED SOLUTIONS

The rotary unions and slip rings shown here are standard designs covering a wide range of applications. If our standard variants are not suitable for your application or your requirements exceed their performance, please do not hesitate to contact us. We can offer you from a wide portfolio of designs that cover most customized solutions.

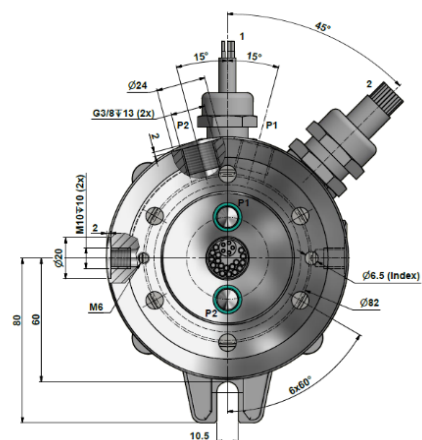
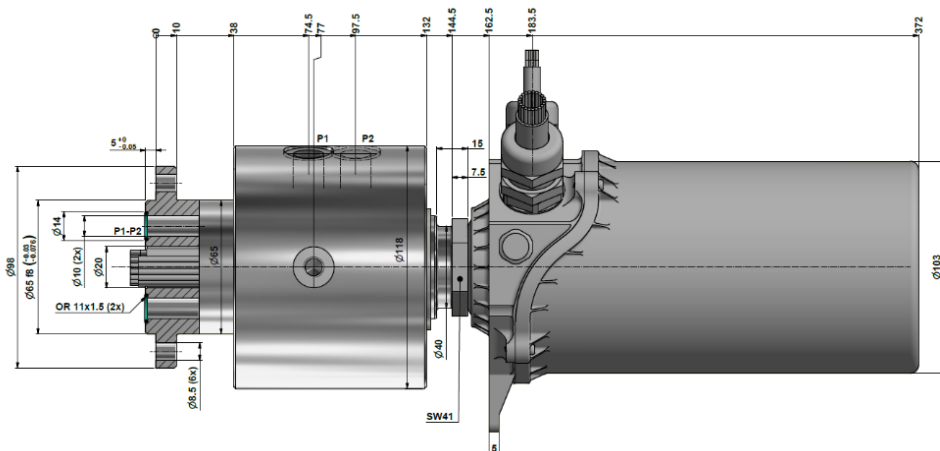

SPECIFICATIONS

Dimensions for counterpart

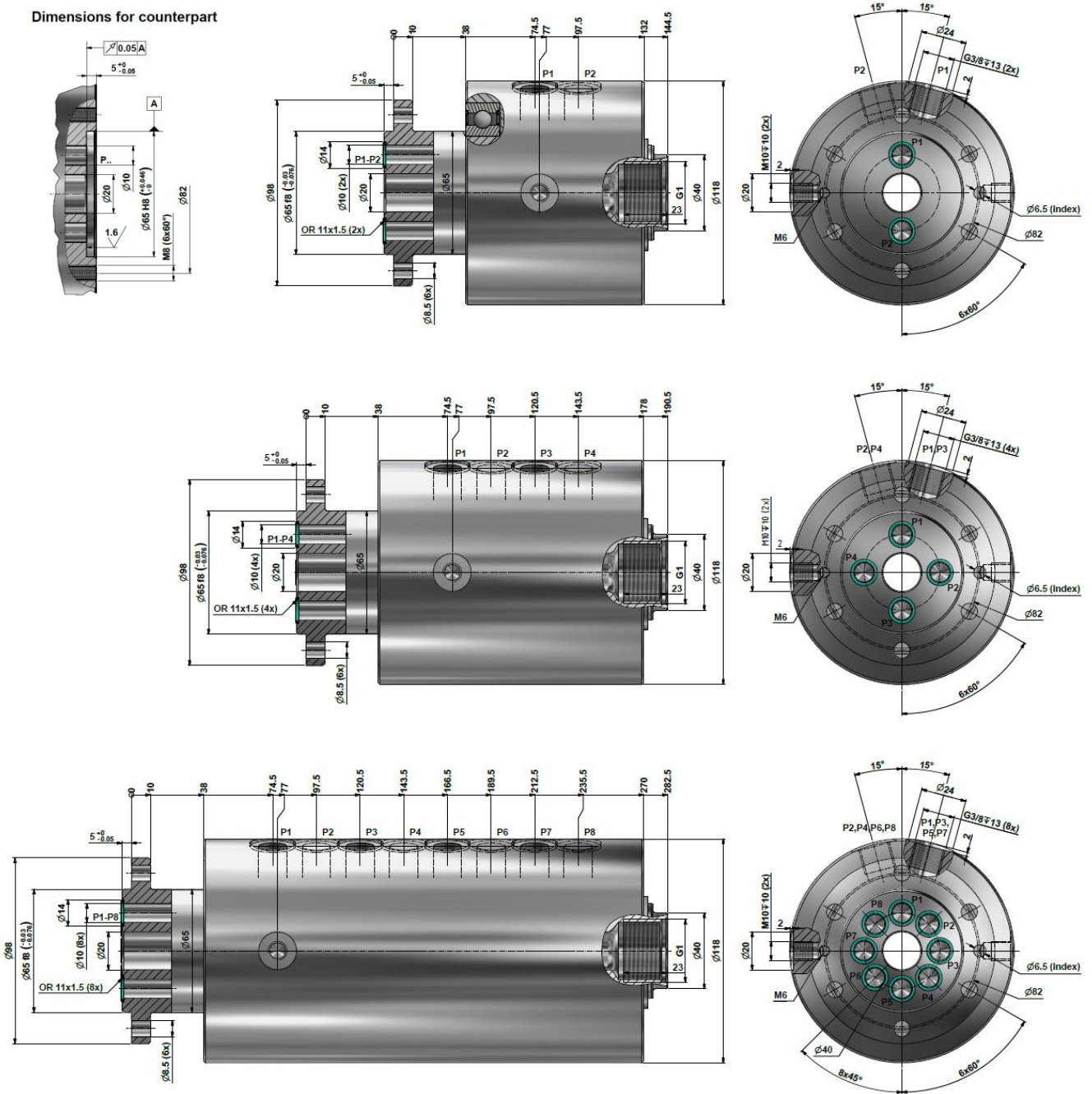

* All rotary unions shown on this page can be combined with all slip rings shown on page 4

Option	M60 X/W/L2-1	M60 X/W/L4-1	M60 X/W/L8-1
Reference drawing	530.2.0.29856 E V02	530.2.0.29856 E V04	530.2.0.29856 E V08
Number of channels	2	4	8
Transferable media	air, water, hydraulic oil		
Max. pressure	see pressure/speed diagram, higher pressures on request		
Max. speed	see pressure/speed diagram, higher revolutions on request		
Operating temperature	-20°C to +80°C		
Humidity	20 to 80% non-condensing		

SPECIFICATIONS

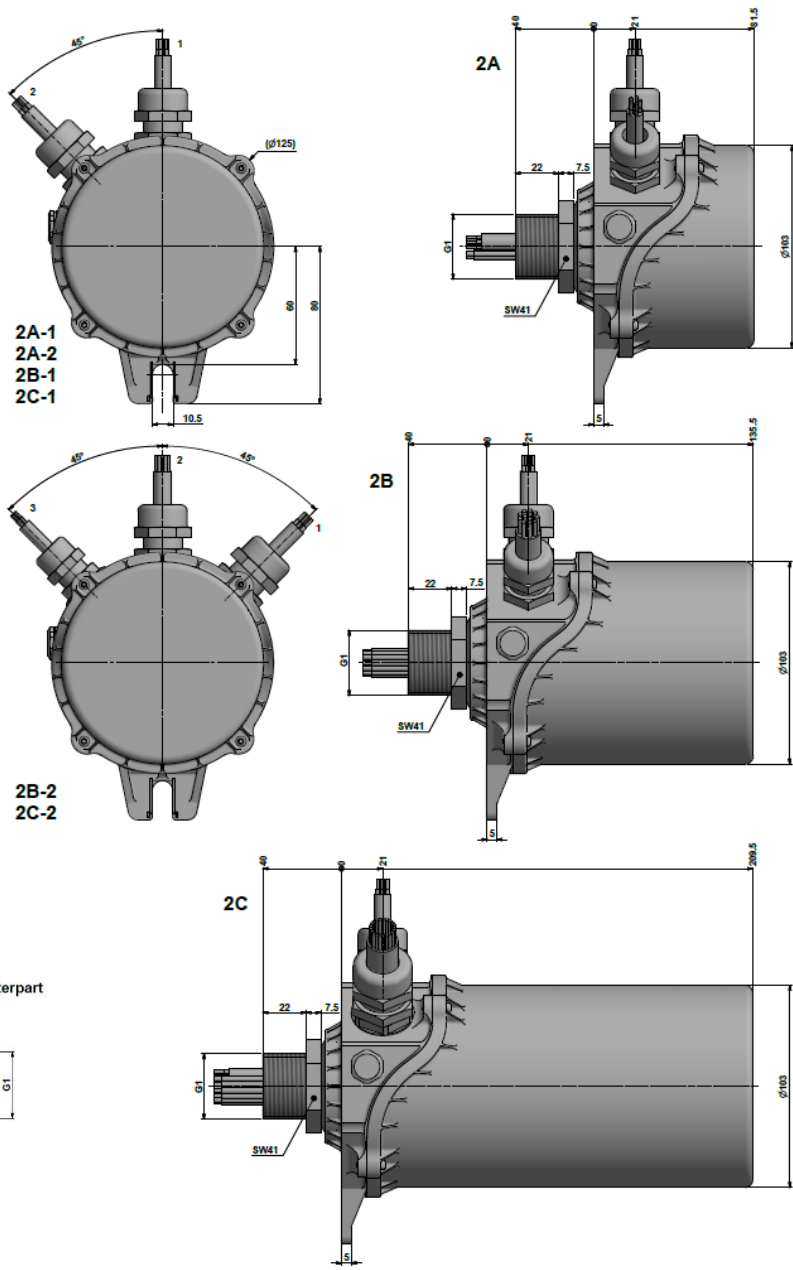

Dimensions for counterpart

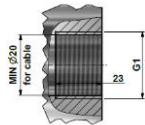

* All slip rings shown on this page can be combined with all rotary unions shown on page 3

F 8000 / 2A-1			F 8000 / 2B-1			F 8000 / 2C-1		
Power:	3x	400VAC / 16A	Power:	3x	400VAC / 16A	Power:	3x	400VAC / 16A
	1x	N		1x	N		1x	N
	1x	PE		1x	PE		1x	PE
Signal:	6x	60VAC/120VDC / 5A	Signal:	12x	60VAC/120VDC / 5A	Signal:	18x	60VAC/120VDC / 5A
F 8000 / 2A-2			F 8000 / 2B-2			F 8000 / 2C-2		
Signal 1:	6x	60VAC/120VDC / 5A	Power:	3x	400VAC / 16A	Power:	3x	400VAC / 16A
Signal 2:	6x	Data (Fast Ethernet, Profinet, DriveCliq, Ethercat (100MBit/s) 100BASE-TX)		1x	N		1x	N
				1x	PE		1x	PE
Signal 1:	6x	60VAC/120VDC / 5A	Signal 1:	6x	60VAC/120VDC / 5A	Signal 1:	12x	60VAC/120VDC / 5A
Signal 2:	6x	Data (Fast Ethernet, Profinet, DriveCliq, Ethercat (100MBit/s) 100BASE-TX)	Signal 2:	6x	Data (Fast Ethernet, Profinet, DriveCliq, Ethercat (100MBit/s) 100BASE-TX)	Signal 2:	6x	Data (Fast Ethernet, Profinet, DriveCliq, Ethercat (100MBit/s) 100BASE-TX)
IP protection class	IP65							
Max. speed	20 rpm							
Operating temperature	-30°C to +60°C							
Cable length	Housing and shaft side 3m							

Pressure/speed-diagram

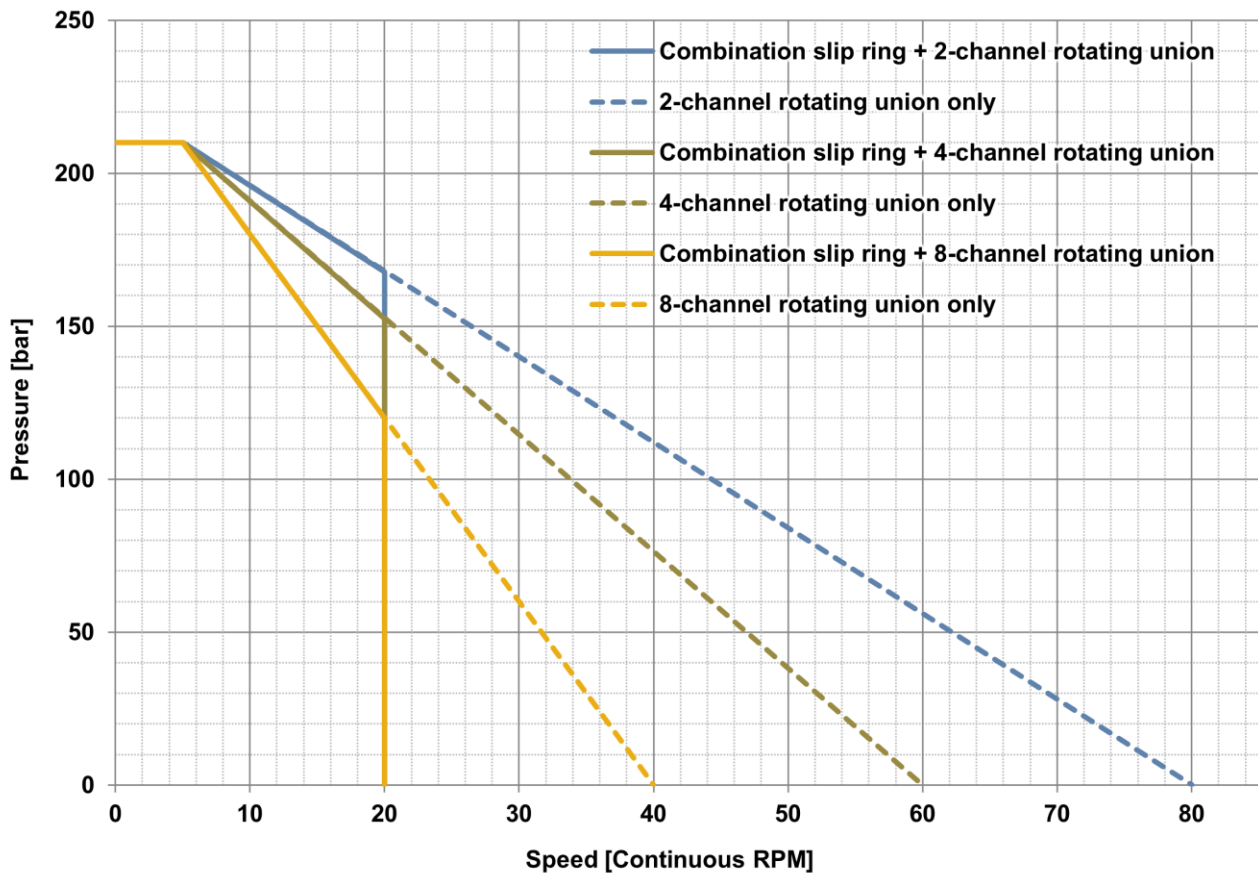

This data is typical and can be used as a general guideline. The real values may be depending on other operating conditions.

Shaft material	Coated steel, stainless steel version on request
Housing material	Anodized aluminum, stainless steel version on request
Bearings	Steel roller bearings 2RS to the atmosphere
Transferable media	
Hydraulic fluids (HL, HLP, HVLP, ATF, HETG, HEES, HEPG, HEPR) ^[1]	
Flame retardant water-containing hydraulic fluids (HFA, HFB, HFC)	
Water ^[2] , water-glycol ^[2,3]	
Gas (air, nitrogen, other technical gases)	
Mineral oil based lubricating greases	
Chemical products, explosive, flammable and other media on request	
^[1] Viscosity	ISO VG 2 to 3200, SAE J300 0W to 60, SAE J 306 70W to 250
^[2] Water hardness	Deionized water up to max. 14°dH
^[3] Mixing ratio	Water-glycol 80/20 to 50/50

THE POWER OF MOOG: COMPLETE ROTARY SOLUTIONS

ROTARY UNION

for the rotary transmission of mediums such as oil, water, grease, air, gas, vacuum



0-100 rpm → Contact Sealing
50-20,000 rpm → Contactless Sealing

SLIP RING

for the rotary transmission of currents, signals and data



Carbon Brushes
Fiber Brushes
Gold/Gold
Silver Rivet

ROTOCAP

for the rotary transmission of high bandwidth data in electrically harsh environments when through bores are required

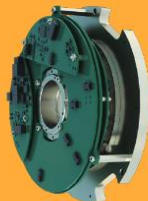

Contactless Capacitive
Transmission Technology

FORJ

for the cost efficient rotary transmission of high bandwidth data in electrically harsh environments when many channels required



Fiber Optic
Rotary Joints

ELECTRONICS

for the transmission, amplification and consolidation of fiber optic and electrical signals and data

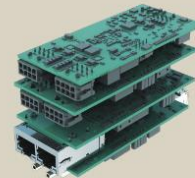

Multiplexers
Repeaters
Switches

THE POWER OF MOOG: COMPLETE ROTARY SOLUTIONS

All the above products are available as standalone solutions or can be integrated in various combinations to create limitless, off-the-shelf and highly customized solutions. As the world market leader of integrated solutions, Moog has the ability to combine products to meet our customer's most challenging and unique rotary transfer needs; we call this the *The Power of Moog: Complete Rotary Solutions*.

EXAMPLES OF WAYS TO BUILD AND COMBINE



Moog GAT GmbH
Industriestraße 11
65366 Geisenheim

Tel.: +49 6722 93788-0
E-Mail: moog-gat.info@moog.com
Website: www.gat-mbh.de

Moog Rekofa GmbH
Bergstrasse 41
53533 Antweiler

Tel: +49 2693 9333 - 0
E-Mail: rekofa.info@moog.com
Website: www.rekofa.net

Moog has offices around the world.
For more information or the office nearest you, contact us online.
rotarysolutions@moog.com

For product information, visit
www.moog.com

Moog is a registered trademark of Moog Inc. and its subsidiaries. All trademarks as indicated herein are the property of Moog Inc. and its subsidiaries.
©2022 Moog Inc. All rights reserved. All changes are reserved.

This technical data is based on current available information and is subject to change at any time. Specifications for specific systems or applications may vary.

MOOG